

# ROUGH TERRAIN CRANE

## **TR-160M**

### *JAPANESE SPECIFICATIONS*

OUTLINE	SPEC. NO.
6-section Boom, 1-staged Jib X-type Outrigger	TR-160M-3-00101

Control No. JA-04

# TR-160M

## CRANE SPECIFICATIONS

### CRANE CAPACITY

6.5m Boom	16,000kg	at 3.0m	( 6part-line)
10.7m Boom	12,000kg	at 4.0m	( 6part-line)
14.9m Boom	9,000kg	at 4.5m	( 4part-line)
19.1m Boom	7,000kg	at 5.5m	( 4part-line)
23.3m Boom	5,000kg	at 6.0m	( 4part-line)
27.5m Boom	3,500kg	at 7.0m	( 4part-line)
3.5m Jib	2,000kg	at 70°	( 1part-line)
Single top	3,000kg		( 1part-line)

### MAX.LIFTING HEIGHT

Boom	27.8m
Jib	31.2m

### MAX.WORKING RADIUS

Boom	24.0m
Jib	26.1m

### BOOM LENGTH

6.5m – 27.5m

### BOOM EXTENSION

21.0m

### BOOM EXTENSION SPEED

21.0m/87s

### JIB LENGTH

3.5m

### MAIN WINCH SINGLE LINE SPEED

110m/min (5th layer)

### MAIN WINCH HOOK SPEED

28.0m/min (4 part-line)

### AUXILIARY WINCH SINGLE LINE SPEED

96m/min (3rd layer)

### AUXILIARY WINCH HOOK SPEED

96m/min (1 part-line)

### BOOM ELEVATION ANGLE

-2° – 82°

### BOOM ELEVATION SPEED

-2° – 82° /35s

### SWING ANGLE

360° continue

### SWING SPEED

2.6min<sup>-1</sup> (rpm)

### WIRE ROPE

Main Winch

14mm x 155m (Diameter x Length)

Spin-resistant wire rope

Auxiliary Winch

14mm x 70m (Diameter x Length)

Spin-resistant wire rope

### BOOM

6-section hydraulically telescoping boom of box construction  
(stages 2,3: synchronized; stages 4,5,6: synchronized)

### BOOM EXTENSION

2 double-acting hydraulic cylinders  
2 wire rope type telescoping devices  
With flow regulator valve with pressure compensation

### JIB

Single stage which swings from and stores under the boom  
Triple offset (5°, 25°, 45°) type

### SINGLE TOP

Mounted and fixed on the top boom section.

### HOIST

Driven by hydraulic motor and via spur gear reducer.  
With free-fall device.  
Automatic brake (with foot brake for free-fall device)  
2 single winches  
With flow regulator valve with pressure compensation

### BOOM ELEVATION

2 double-acting hydraulic cylinders  
With flow regulator valve with pressure compensation

### SWING

Hydraulic motor driven planetary gear reducer  
Swing bearing  
Swing free/lock changeover type  
Negative brake

### OUTRIGGERS

Fully hydraulic X-type (floats mounted integrally)  
Slides and jacks each provided with independent operation device.

Fully extended width	5.2m
Middle extended width	4.8m, 4.4m
Minimum extended width	3.2m

### OPERATION METHOD

Hydraulic pilot valve operation

**MAX. VERTICAL LOAD CAPACITY OF OUTRIGGER**  
18.3t

### HYDRAULIC PUMPS

2 variable piston pumps  
2 gear pumps

### HYDRAULIC OIL TANK CAPACITY

295 liters

### SAFETY DEVICES

Automatic moment limiter (AML)  
Swing automatic stop device  
Over-winding cutout device  
Working area control device  
Free-fall interlock device  
Outrigger extension width detector  
Level gauge  
Hook safety latch  
Hydraulic safety valve  
Telescopic counterbalance valve  
Elevation counterbalance valve  
Jack pilot check valve

### EQUIPMENT

Air-conditioner with dehumidifier  
Hydraulic oil temperature indication lamp  
Radio  
Oil cooler  
Visual-type winch drum rotation indicator  
Operation pedals  
ISO arrangement: for telescoping/auxiliary hoisting  
TADANO arrangement: for elevating/telescoping

## CARRIER SPECIFICATIONS

### ENGINE

Model HINO H07C-TF  
 Type 4-cycle, 6-cylinder, direct-injection, water-cooled diesel engine (with turbo charger)  
 Piston displacement 6,728cc  
 Max. output 162kW at 2,800rpm(220PS at 2,800rpm)  
 Max. torque 657N·m at 1,600rpm(67.0kgf·m at 1,600rpm)

### TORQUE CONVERTER

3-element, 1-stage unit (with automatic lock-up mechanism)

### TRANSMISSION

Power shift type (wet multi-plate clutch)  
 4 forward and 1 reverse speeds (with Hi/Low settings)

### REDUCER

Axle dual-ratio reduction

### DRIVE

2-wheel drive (4X2) / 4-wheel drive (4X4) selection

### FRONT AXLE

Full floating type

### REAR AXLE

Full floating type

### SUSPENSION

Front Parallel leaf spring type  
 Rear Parallel leaf spring type

### STEERING

Fully hydraulic power steering  
 With reverse steering correction mechanism

### BRAKE SYSTEM

Service Brake  
     Hydro-pneumatic brake  
     Disk brake  
 Parking Brake  
     Mechanically operated, internal expanding duo-servo shoe type acting on drum at transmission case rear.  
 Auxiliary Brake  
     Electro-pneumatic operated exhaust brake  
     Eddy current retarder  
     Auxiliary braking device for operations

### FRAME

Welded box-shaped structure

### ELECTRIC SYSTEM

12 V DC. 2 batteries of 24V (120Ah)

### FUEL TANK CAPACITY

250 liters

### TIRES

Front 325/95R24 161E ROAD  
 Rear 325/95R24 161E ROAD

### CAB

One-man type  
 With interior equipment  
 Liquid filled rubber mounted type  
 Fully adjustable foldable seat (with headrest and seat belt)  
 Adjustable handle (tilt, telescoping)  
 Intermittent type windshield/roof wiper (with washer)  
 Power window  
 Side visor

### SAFETY DEVICES

Emergency steering device  
 Spring lock device  
 Rear wheel steering lock device  
 Engine over-run alarm  
 Overshift prevention device  
 Parking brake alarm

### EQUIPMENT

Centralized oiling device  
 Electric mirror

## GENERAL DATA

### DIMENSIONS

Overall length	8,520mm
Overall width	2,200mm
Overall height	3,140mm
Wheel base	3,200mm
Tread Front	1,820mm
Rear	1,820mm

### WEIGHTS

Gross vehicle weight	
Total	19,895kg
Front	9,950kg
Rear	9,945kg

### PERFORMANCE

Max. traveling speed	49km/h
Gradeability (tan $\theta$ )	0.6
Min. turning radius	5.1m (4-wheel steering) 8.7m (2-wheel steering)

**TOTAL RATED LOADS**

(1) With outriggers set  
[BOOM]

Unit : ton

Outriggers fully extended (5.2m)							-360° -
A \ B	6.5m	10.7m	14.9m	19.1m	23.3m	27.5m	
2.5m	16.00	12.00	9.00	7.00			
3.0m	16.00	12.00	9.00	7.00			
3.5m	14.00	12.00	9.00	7.00	5.00	3.50	
4.0m	12.50	12.00	9.00	7.00	5.00	3.50	
4.5m	11.50	11.10	9.00	7.00	5.00	3.50	
5.0m		10.25	8.90	7.00	5.00	3.50	
5.5m		9.40	8.20	7.00	5.00	3.50	
6.0m		8.80	7.60	6.60	5.00	3.50	
7.0m		6.75	6.40	5.80	4.70	3.50	
8.0m		5.30	5.00	5.00	4.15	3.35	
9.0m		4.30	4.00	4.25	3.70	3.00	
10.0m		(8.7m)	3.25	3.50	3.30	2.75	
11.0m			2.65	2.95	3.00	2.50	
12.0m			2.15	2.45	2.70	2.30	
13.0m			1.80	2.05	2.30	2.10	
14.0m			(12.9m)	1.75	2.00	1.95	
15.0m				1.45	1.70	1.75	
16.0m				1.25	1.45	1.50	
17.0m				1.05	1.25	1.30	
18.0m					1.05	1.10	
19.0m					0.90	0.95	
20.0m					0.75	0.80	
22.0m					0.60	0.60	
24.0m					(21.3m)	0.45	
a (°)	0 ~ 82						

A= Boom length B= Working radius  
a= Boom angle range (for the unladen condition)

## [BOOM]

Unit: ton

		Outriggers middle extended (4.8m)				-Over sides-	
A \ B		6.5m	10.7m	14.9m	19.1m	23.3m	27.5m
2.5m		16.00	12.00	9.00	7.00		
3.0m		16.00	12.00	9.00	7.00		
3.5m		14.00	12.00	9.00	7.00	5.00	3.50
4.0m		12.50	12.00	9.00	7.00	5.00	3.50
4.5m		11.50	11.10	9.00	7.00	5.00	3.50
5.0m			10.25	8.90	7.00	5.00	3.50
5.5m			9.20	8.20	7.00	5.00	3.50
6.0m			7.90	7.60	6.60	5.00	3.50
7.0m			5.85	5.85	5.80	4.70	3.50
8.0m			4.55	4.50	4.85	4.15	3.35
9.0m			3.80	3.55	3.90	3.70	3.00
10.0m			(8.7m)	2.85	3.15	3.30	2.75
11.0m				2.30	2.60	2.80	2.50
12.0m				1.85	2.15	2.35	2.30
13.0m				1.50	1.75	1.95	2.10
14.0m				(12.9m)	1.45	1.65	1.75
15.0m					1.20	1.40	1.50
16.0m					1.00	1.20	1.25
17.0m					0.85	1.00	1.05
18.0m						0.85	0.90
19.0m						0.70	0.75
20.0m						0.55	0.60
22.0m							0.40
a (°)		0~82				22~82	32~82

A= Boom length B= Working radius

a= Boom angle range (for the unladen condition)

[BOOM]

Unit : ton

		Outriggers middle extended (4.4m)				-Over sides-	
A \ B		6.5m	10.7m	14.9m	19.1m	23.3m	27.5m
2.5m		16.00	12.00	9.00	7.00		
3.0m		16.00	12.00	9.00	7.00		
3.5m		14.00	12.00	9.00	7.00	5.00	3.50
4.0m		12.50	12.00	9.00	7.00	5.00	3.50
4.5m		11.50	11.10	9.00	7.00	5.00	3.50
5.0m			9.50	8.90	7.00	5.00	3.50
5.5m			8.05	7.90	7.00	5.00	3.50
6.0m			6.85	6.70	6.60	5.00	3.50
7.0m			5.05	5.00	5.35	4.70	3.50
8.0m			3.85	3.85	4.15	4.15	3.35
9.0m			3.20 (8.7m)	3.00	3.30	3.55	3.00
10.0m				2.35	2.65	2.90	2.75
11.0m				1.85	2.15	2.35	2.50
12.0m				1.45	1.75	1.95	2.10
13.0m				1.10 (12.9m)	1.40	1.60	1.75
14.0m						1.15	1.35
15.0m					0.95	1.10	1.25
16.0m					0.75	0.90	1.05
17.0m					0.60	0.75	0.85
18.0m						0.60	0.70
19.0m							0.55
20.0m							0.40
a (°)		0~82			10~82	34~82	40~82

A= Boom length B= Working radius  
a= Boom angle range (for the unladen condition)

[BOOM]

Unit: ton

		Outriggers minimum extended (3.2m)				-Over sides-	
B \ A	6.5m	10.7m	14.9m	19.1m	23.3m	27.5m	
	2.5m	16.00	12.00	9.00	7.00		
3.0m	14.50	12.00	9.00	7.00			
3.5m	10.50	10.40	9.00	7.00	5.00	3.50	
4.0m	8.00	8.25	7.75	7.00	5.00	3.50	
4.5m	6.50	6.60	6.30	7.00	5.00	3.50	
5.0m		5.45	5.30	5.80	5.00	3.50	
5.5m		4.60	4.40	4.90	5.00	3.50	
6.0m		3.90	3.75	4.15	4.40	3.50	
7.0m		2.90	2.75	3.10	3.30	3.25	
8.0m		2.20	2.05	2.35	2.60	2.70	
9.0m		1.70 (8.7m)	1.50	1.80	2.05	2.15	
10.0m			1.10	1.40	1.60	1.70	
11.0m			0.75	1.05	1.25	1.35	
12.0m			0.50	0.80	0.95	1.10	
13.0m				0.55	0.75	0.85	
14.0m				0.40	0.55	0.65	
15.0m					0.40	0.50	
a (°)	0~82		24~82	36~82	46~82	55~82	

A= Boom length B= Working radius  
a= Boom angle range (for the unladen condition)

[JIB]

Outriggers fully extended (5.2m) -360° -						
C	27.5m Boom + 3.5m Jib					
	5° ☒		25° ☒		45° ☒	
E (°)	B (m)	M (t)	B (m)	M (t)	B (m)	M (t)
82	4.2	2.00	5.1	1.50	6.1	1.25
75	8.1	2.00	8.8	1.50	9.8	1.25
70	10.8	2.00	11.4	1.50	12.3	1.25
65	13.2	1.60	13.8	1.35	14.6	1.25
60	15.5	1.35	16.1	1.15	16.8	1.15
55	17.7	1.05	18.2	1.10	18.8	1.00
50	19.7	0.85	20.1	0.80	20.7	0.80
45	21.6	0.65	21.9	0.60	22.3	0.60
40	23.2	0.50	23.5	0.45		
35	24.7	0.35	24.9	0.35		
30	26.0	0.25	26.1	0.25		
a (°)	29~82			44~82		

Outriggers middle extended (4.8m) -Over sides-						
C	27.5m Boom + 3.5m Jib					
	5° ☒		25° ☒		45° ☒	
E (°)	B (m)	M (t)	B (m)	M (t)	B (m)	M (t)
82	4.2	2.00	5.1	1.50	6.1	1.25
75	8.1	2.00	8.8	1.50	9.8	1.25
70	10.8	2.00	11.4	1.50	12.3	1.25
65	13.2	1.60	13.8	1.35	14.6	1.25
60	15.5	1.25	16.1	1.15	16.8	1.15
55	17.6	0.90	18.2	0.85	18.8	0.85
50	19.7	0.65	20.1	0.65	20.6	0.60
45	21.5	0.45	21.9	0.50	22.3	0.45
40	23.2	0.35	23.5	0.35		
a (°)	39~82			44~82		

Outriggers middle extended (4.4m) -Over sides-						
C	27.5m Boom + 3.5m Jib					
	5° ☒		25° ☒		45° ☒	
E (°)	B (m)	M (t)	B (m)	M (t)	B (m)	M (t)
82	4.2	2.00	5.1	1.50	6.1	1.25
75	8.1	2.00	8.8	1.50	9.8	1.25
70	10.8	2.00	11.4	1.50	12.3	1.25
65	13.1	1.45	13.8	1.35	14.6	1.25
60	15.4	1.00	16.0	1.00	16.8	0.90
55	17.6	0.70	18.1	0.70	18.7	0.65
50	19.6	0.50	20.1	0.50	20.6	0.45
45	21.5	0.30	21.9	0.30	22.2	0.30
a (°)	44 ~ 82					

Outriggers minimum extended (3.2m) -Over sides-						
C	27.5m Boom + 3.5m Jib					
	5° ☒		25° ☒		45° ☒	
E (°)	B (m)	M (t)	B (m)	M (t)	B (m)	M (t)
82	4.2	2.00	5.1	1.50	6.1	1.25
75	8.1	2.00	8.8	1.50	9.8	1.25
72	9.6	1.50	10.3	1.30	11.3	1.25
70	10.6	1.20	11.3	1.10	12.2	1.05
65	13.0	0.75	13.7	0.70	14.4	0.65
60	15.3	0.40	16.0	0.35	16.6	0.35
a (°)	59 ~ 82					

B= Working radius C= Jib length D= Jib offset  
 E= Boom angle M= Total rated loads  
 a= Boom angle range (for the unladen condition)



**PRECAUTIONS TO BE TAKEN WHEN THE OUTRIGGERS ARE EXTENDED:**

1. The total rated loads shown are for the case where the crane is set horizontally on firm level ground. They include the weights of the slings and hooks (main hook: 160kg, auxiliary hook: 60kg).  
The values above the bold lines are based on the crane strength while those below are based on the crane stability.
2. Since the working radii are based on the actual values including the deflection of the boom, operations should be performed in accordance with the working radii.
3. Jib operations should be performed in accordance with the boom angle, irrespective of the boom length. The working radii are reference values for the case where the jib is mounted on a 27.5m boom.
4. The total rated load for the single top shall be the value obtained by subtracting the weight of the hook mounted on the boom from the total rated load of the boom and must not exceed 3.0t.
5. As a rule, free-fall operation should be performed only when lowering the hook alone. If a hoisted load must be lowered by free-fall operation, the load must be kept below 1/5th of the total rated load and sudden braking operations must be avoided.
6. The chart below shows the standard number of part lines for each boom length. The load per line should not exceed 26.2kN (2.67tf) for the main winch and 29.4kN (3.0tf) for the auxiliary winch.

A	6.5m	10.7m	14.9m	19.1m	23.3m	27.5m	Single top
H	6	6	4	4	4	4	1

A= Boom length H= No. of part-lines

7. The hoisting performance for the "Over sides" range will differ according to the extended width of the outriggers. Operations should be performed in accordance with the performance corresponding to the extended width. Also, although the hoisting performances for the "Over front" and "Over rear" ranges are equivalent to those of the "outriggers fully extended" condition, the front and rear ranges (angle a) will differ according to the width to which the outriggers are extended in the left and right directions.

Extended width	Middle extended (4.8m)	Middle extended (4.4m)	Minimum extended (3.2m)
Angle a° ☒	30	25	15

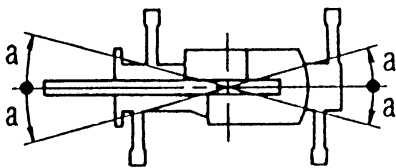

(2) Without outriggers

Unit: ton

B (m)	Stationary											
	6.5m Boom		10.7m Boom		14.9m Boom		19.1m Boom					
	F	G	F	G	F	G	F	G				
3.0	8.00	4.40	7.50	4.50	7.00	4.65	5.50	5.00				
3.5	7.70	3.50	7.50	3.65	7.00	3.70	5.50	4.00				
4.0	7.30	2.80	7.30	2.90	6.80	3.00	5.50	3.15				
4.5	6.60	2.20	6.40	2.40	5.75	2.40	5.35	2.50				
5.0			5.45	1.90	4.85	1.85	5.00	2.00				
5.5			4.60	1.50	4.15	1.40	4.45	1.65				
6.0			3.95	1.15	3.70	1.05	3.90	1.35				
7.0			3.00	0.60	3.00	0.50	3.00	0.85				
8.0			2.30		2.30		2.45	0.45				
9.0					1.70		1.90					
10.0					1.25		1.45					
11.0					0.95		1.15					
12.0					0.65		0.85					
13.0							0.60					
14.0							0.40					
a (°)	0~82		38~82		24~82		57~82		36~82		62~82	

Unit: ton

B (m)	Creep (travelling at 1.6km/h or less)											
	6.5m Boom		10.7m Boom		14.9m Boom		19.1m Boom					
	F	G	F	G	F	G	F	G				
3.0	6.70	3.70	6.30	3.80	5.90	3.80	4.60	4.20				
3.5	6.50	2.95	6.30	3.00	5.90	3.10	4.60	3.35				
4.0	6.10	2.35	6.00	2.45	5.75	2.50	4.60	2.65				
4.5	5.50	1.85	5.40	2.00	4.85	2.00	4.50	2.10				
5.0			4.60	1.60	4.10	1.55	4.20	1.65				
5.5			3.85	1.25	3.50	1.15	3.70	1.35				
6.0			3.00	0.95	3.10	0.85	3.50	1.10				
7.0			2.50	0.50	2.50	0.40	2.50	0.70				
8.0			1.90		1.90		2.05					
9.0					1.40		1.60					
10.0					1.05		1.20					
11.0					0.80		0.95					
12.0					0.55		0.70					
13.0							0.50					
a (°)	0~82		38~82		24~82		57~82		42~82		65~82	

B= Working radius F= Front G= 360°  
a= Boom angle range (for the unladen condition)

**PRECAUTIONS TO BE TAKEN WHEN THE OUTRIGGERS ARE NOT MOUNTED:**

1. The total rated loads shown are for the case where the tire air pressure on firm level ground is as specified (900kPa (9.00kgf/cm<sup>2</sup>)) and the crane is completely spring-locked. They include the weights of the slings and hooks (main hook: 160kg, auxiliary hook: 60kg).  
The values above the bold lines are based on the crane strength while those below are based on the crane stability. The foundation, working conditions, etc. should be taken into consideration for actual work.
2. Since the working radii are based on the actual values including the deflection of the boom and the tires, operations should be performed in accordance with the working radii.
3. The chart below shows the standard number of part lines for each boom length. The load per line should not exceed 26.2kN (2.67tf) for the main winch and 29.4kN (3.0tf) for the auxiliary winch.

A	6.5m	10.7m	14.9m	19.1m	Single top
H	4	4	4	4	1

A= Boom length H= No. of part-lines

4. "Over front" crane operations should be performed only when the AML "over-front area indicator lamp" is lit. The boom must be kept inside a 2° area over front of the carrier when performing "Over front" crane operations without the outriggers.

Approx. 2°

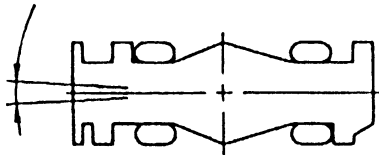

5. The total rated load for the single top shall be the value obtained by subtracting the weight of the hook mounted on the boom from the total rated load of the boom and must not exceed 3.0t.
6. Free-fall operations should not be performed without outriggers.  
Booms over 19.1m in length and jibs should not be used without outriggers.
7. The "Drive Mode Selection" switch should be set to "4-wheel·Lo" for creeping while hoisting a load and the shift lever should be set to first.
8. When creeping while hoisting a load, the swing brake should be applied, the load should be kept as close to the ground as possible but not touching the ground and the speed should be kept at 1.6km/h or less. In particular, any abrupt steering, starting or braking must be avoided.
9. Crane operations should not be performed when creeping while hoisting a load.

**WORKING RADIUS - LIFTING HEIGHT**

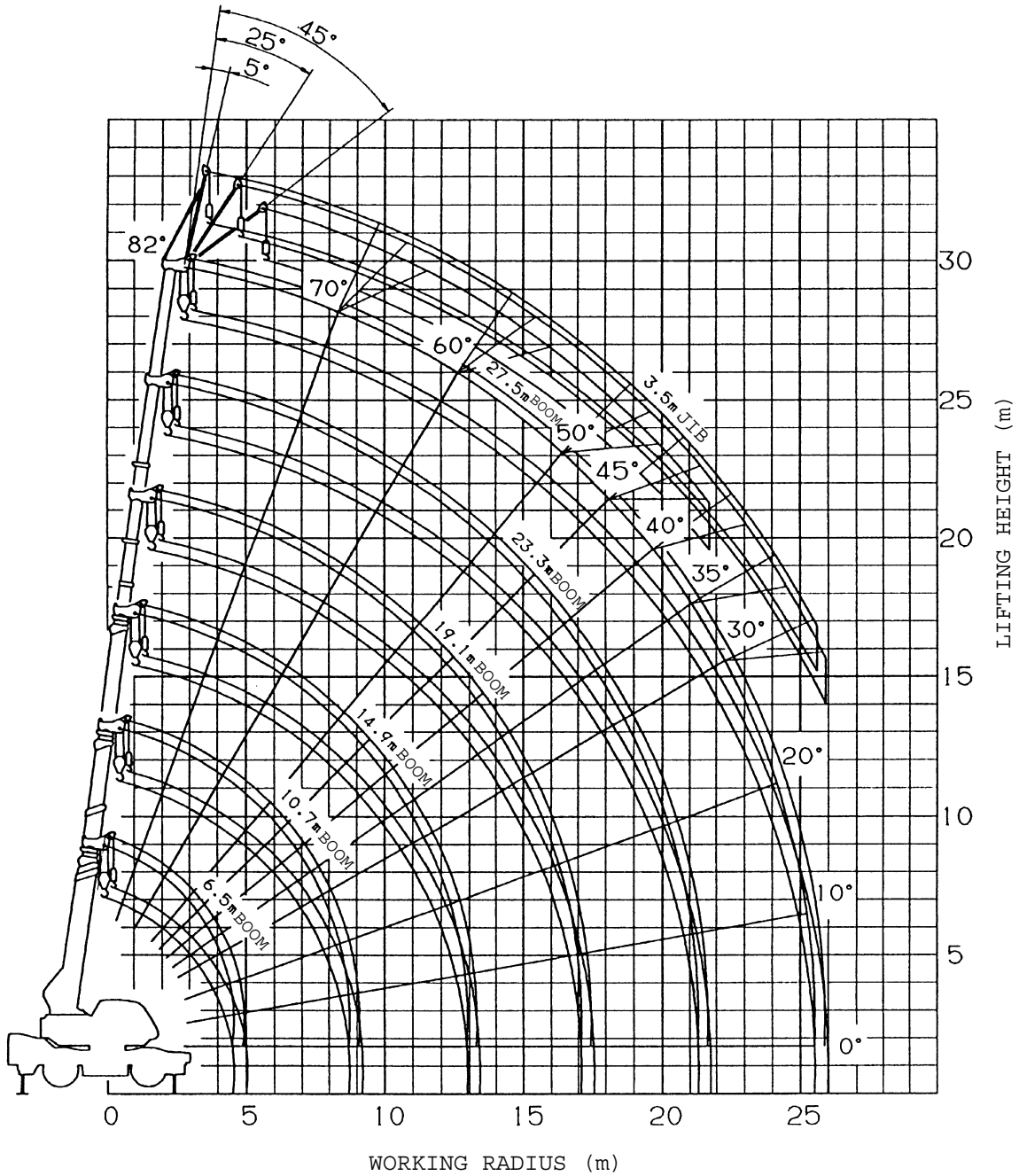

**NOTES:**

1. The deflection of the boom is not incorporated in the figure above.
2. The figure above is for the case where the outriggers are fully extended (360°).

**DIMENSIONS** (1/100)

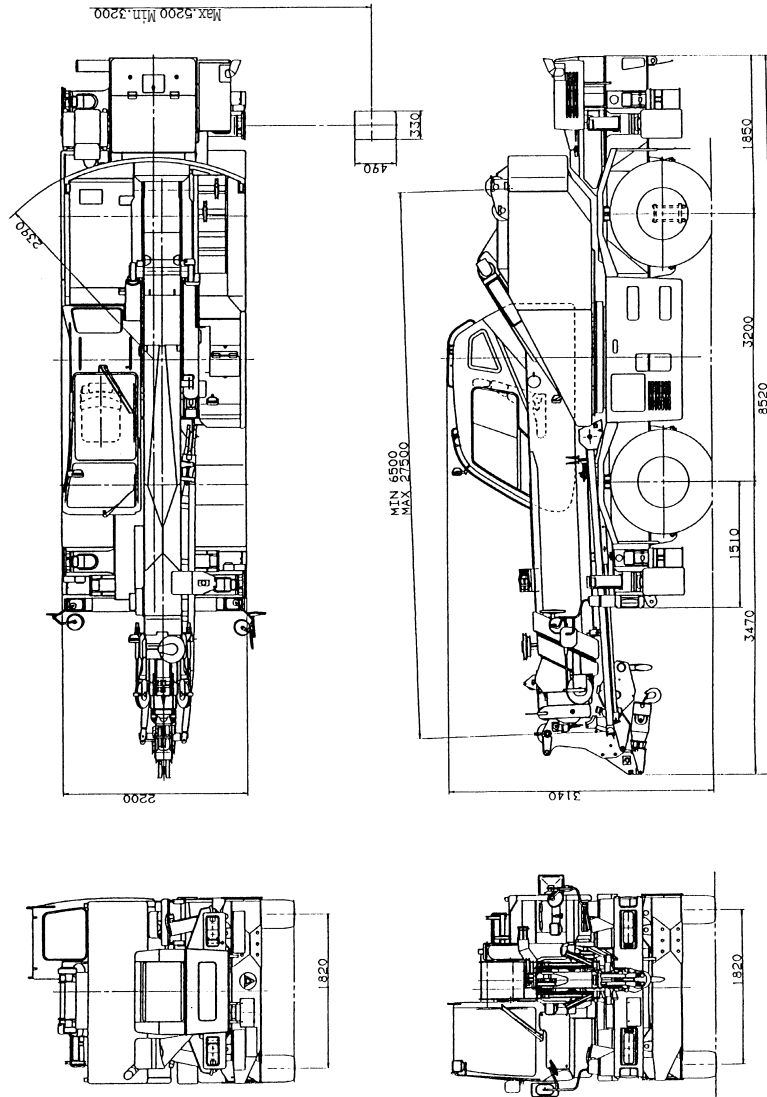

◆ M E M O ◆

-----

-----

-----

-----

-----

-----

-----

-----

-----

-----

-----

-----

-----

-----

-----

-----

-----

-----

-----

-----

-----

-----

-----

-----

-----

-----

-----

-----